



# Islander

Follow us @CityofSIB |     YouTube

JUNE 2022

## A MESSAGE FROM THE Mayor

“ This June we celebrate Sunny Isles Beach’s 25th anniversary. On June 16, 1997, the city was officially incorporated, establishing our nearly two square miles of land as a municipality. ”



Dana Robin Goldman  
Mayor

Things moved quickly after incorporation – a Charter Commission was appointed, City Charter adopted and city administration hired.

The first City Hall was rented office space in an RK shopping plaza where a small group of employees worked in a bare, concrete floor room with four desks, four chairs on wheels, and four phones. From there, more departments were established such as building, planning & zoning, code enforcement, and most essentially, police. With a vision from its founders, Sunny Isles Beach quickly developed from run-down and crime-ridden to prosperous and family-friendly.

Sunny Isles Beach is, by all means, a young city. Which is why achieving such growth in this short amount of time, 25 years, is remarkable. Once known as “Motel Row” and notorious for a slew of disadvantageous activity, this city has transformed into a desirable, diverse and safe community. People from all walks of life live here, work here, learn here, and play here. We commemorate the past 25 years and look toward the future.

One way we honor our successes is with our 25th Anniversary Celebration. I invite the entire community

to our celebratory events happening this month. On May 21 we held the first anniversary event, Walk ‘n Roll, and had a blast with everyone who participated in the community walk and carnival.

This month don’t miss The Isles After Dark, a charity gala benefiting Mount Sinai Medical Center. Join us on Saturday, June 4 at 6 p.m. for an evening of dinner, dancing, and drinks all for a meaningful cause. The festivities culminate on Sunday, June 12 with Celebration of the Isles. With live music by the Pop 2000 Tour, food trucks and fireworks, the event is perfect for the whole family. You can find out more about the events on pages 4 and 5. We hope to see you there!

This month and every month this year we celebrate our 25th anniversary. We celebrate our vibrant community, our local businesses, and our stunning natural environment. We celebrate our public safety officers, our city staff, and commission.

I am proud to live here and thank all of you for making Sunny Isles Beach your home. There is still much to do and I am grateful for the opportunity to continue serving our community.

# CALENDAR OF EVENTS

## JUNE

### Environment Sustainability Advisory Committee Meeting

**Wednesday, June 1**  
**12 PM**  
Government Center 1st Floor Meeting Room,  
18070 Collins Ave.

### Blood Pressure, Cholesterol & Glucose Screening

**Thursday, June 2**  
**9:30 - 11 AM**  
Gateway Center, 151 Sunny Isles Blvd.

### The Isles After Dark A Charity Gala

**Saturday, June 4**  
**6 - 9 PM**  
Gateway Center, 151 Sunny Isles Blvd.  
**Residents:** \$75  
**Non-Residents:** \$125  
More info on [page 4!](#)

### Golden Era Movie: Oliver

**Tuesday, June 7 | 10 AM - 1 PM**  
Gateway Center, 151 Sunny Isles Blvd.  
**Residents:** FREE  
**Non-Residents:** \$5

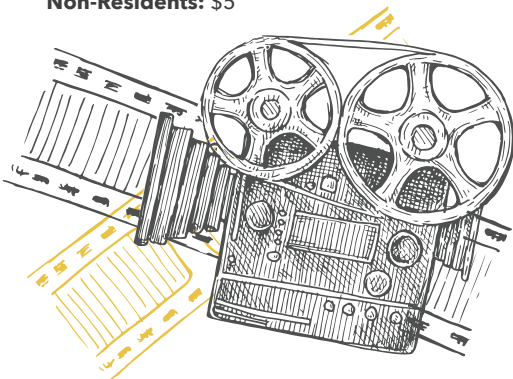

**June 8 and 22**  
**Wednesday | 3 - 4 PM**  
Gateway Center, 151 Sunny Isles Blvd.

### Teens Only: DJ Party

**Wednesday, June 8**  
**7 - 9 PM**  
Pelican Community Park,  
18115 North Bay Road  
FREE



### Celebration of the Isles

**Sunday, June 12**  
**5 - 9 PM**  
Gateway Park, 151 Sunny Isles Blvd.  
**Residents:** FREE  
**Non-Residents:** \$15  
More info on [page 5!](#)

### Lunch n' Learn with Florida Historian, Cesar Becerra

**Tuesday, June 14**  
**FREE**  
**11 - 11:45 AM**  
Gateway Center,  
151 Sunny Isles Blvd.  
Snacks will be available  
for purchase.

Pre-registration required.



### Full Moon Yoga

**Tuesday, June 14**  
**7:45 - 8:45 PM**  
Samson Oceanfront Park (on the beach),  
17425 Collins Ave.  
**Residents:** FREE  
**Non-Residents:** \$5  
Pre-registration required.

### Special Magistrate Hearing

**Wednesday, June 15**  
**10 AM - 12 PM**  
Commission Chambers  
Government Center, 18070 Collins Ave.

### Concert in the Park Happy Daze

**Wednesday,**  
**June 15**  
**7:30 - 9 PM**  
**FREE**  
Samson Oceanfront Park,  
17425 Collins Avenue



### Regular City Commission Meeting

**Thursday, June 16**  
**6:30 PM**  
Commission Chambers  
Government Center, 18070 Collins Ave.

### Federal Holiday: Juneteenth

**Monday, June 20**  
City Facilities Closed



**FOR COMPLETE EVENT  
DETAILS, VISIT**

[sibfl.net/events](http://sibfl.net/events)

# SPOTLIGHT ON...

## EVENTS



As we celebrate the City's 25th anniversary this month, we want to spotlight our Special Events division who work year-round to bring a variety of events to the community. From the Anniversary Celebration to Booogie by the Beach to concerts in the park, the Events team is always planning your next night out or a fun day at the park. But it's not all fun and games. There are detailed planning, coordination and financial decisions that must get made on a daily basis. Despite the hard work, our events team loves what they do for the community and can't wait to see you at our events this year!

Check out our event calendar online at [sibfl.net/events](http://sibfl.net/events).

# INSIDE THE *Isles*

## Flood Protection

We are entering the rainy season, which means the city is susceptible to flash flooding if we experience strong storm conditions.

There are many ways you can help prevent severe flooding:

- Avoid dumping and throwing trash and debris in drains and ditches
- Regularly check and clean gutters
- If you see dumping or debris in ditches or streams, please call the Public Works department at [305.792.1711](tel:305.792.1711).

If you know a flood is coming, shut off the gas and electricity and move valuable contents to a safe place. It is unlikely you will get much warning, so preparing a detailed checklist in advance is a good idea.

- Do not walk or drive through a flooded area.
- Stay away from power lines and electrical wires.
- Look out for animals, especially snakes.
- Be alert for gas leaks.
- Evacuate if mandated.

If you don't have flood insurance, talk to your insurance agent. Homeowner's insurance policies do not cover damage from floods. However, Sunny Isles Beach participates in the National Flood Insurance Program, and you can purchase a separate flood insurance policy. This insurance is backed by the Federal government and available to everyone, even for properties that have been flooded.

For more information about protecting your home from flooding, visit [sibfl.net/flood-protection](http://sibfl.net/flood-protection).

# HURRICANE PREPAREDNESS

June marks the start of Hurricane Season, which means it's time to prepare if you haven't already. The season lasts until November 30 and scientists predict another above-average season.

Make sure your supply kit is stocked with the essentials, prepare an evacuation route, and identify key news and government sources of trusted information.

### Stay Connected



Sign up for storm alerts and City updates delivered straight to your phone or inbox at [sibalert.net](http://sibalert.net).

**SIB Police Department:**  
[305.947.4440](tel:305.947.4440)

**Before the Storm**  
[sibfl.net/hurricane](http://sibfl.net/hurricane)

**Email Notifications**  
[sibfl.net/notifyme](http://sibfl.net/notifyme)

**During/After a Storm:**  
[sibfl.net/emergency](http://sibfl.net/emergency)

FOLLOW US: @CityofSIB | @SIBPD  

## HURRICANE ESSENTIALS

- Water  
*(one gallon per person per day for several days, for drinking and sanitation)*
- Food  
*(at least a three-day supply of non-perishable food)*
- Battery-powered or hand crank radio
- Flashlight
- First aid kit
- Prescription medications
- Extra batteries
- Manual can opener
- Local maps
- Cell phone with chargers and a backup battery





CELEBRATING OUR **25<sup>th</sup>** ANNIVERSARY

# The Isles After Dark

*A Charity Gala benefiting  
Mount Sinai Medical Center*

SATURDAY, JUNE 4  
6 PM  
GATEWAY CENTER

Sip on our signature cocktail as you enjoy  
a sophisticated evening of dining, live  
entertainment, and more.

**\$75** | **\$125**

*with valid City-issued  
Resident ID Card*

*Without*

[SIBFL.NET/ANNIVERSARY](https://www.sibfl.net/anniversary)



CELEBRATING OUR **25<sup>th</sup>** ANNIVERSARY

# Celebration of the Isles

SUNDAY, JUNE 12

5 - 9 PM

GATEWAY PARK

Featuring Pop 2000 Tour hosted by Chris Kirkpatrick of \*NSYNC, with O-Town, Ryan Cabrera & LFO

**LIVE MUSIC | ACTIVITIES**  
**FOOD TRUCKS | FIREWORKS**

**WRISTBANDS**

**FREE | \$15**

*with valid City-issued  
Resident ID Card*

*Without*

**FIREWORKS BEGIN AT 9:30 PM ON THE BEACH**

*Fireworks will be launched from the ocean (near 174th Street)  
and can be viewed from anywhere on the beach.*

**[SIBFL.NET/ANNIVERSARY](http://SIBFL.NET/ANNIVERSARY)**

# ART CONTEST

Shine your light & showcase  
your artwork!

As a part of the City's 25th anniversary, we want to shed light on our talented local artists.

Our Sunny Spaces Art Contest gives local artists the opportunity to have a lasting impact on our community.

Artists will either paint or hand draw an original 8" x 8" piece, incorporating our theme of a sun in the artwork. If selected, the artwork will be recreated in various locations around Sunny Isles Beach.

We are excited to see your submissions and to have our local artists' work showcased for all of Sunny Isles Beach to enjoy!

**SUBMISSION DEADLINE:**

July 1, 2022

**SUBMISSION LOCATION:**

Sunny Isles Beach Visitor Center,  
18070 Collins Avenue

**FOR MORE INFORMATION, VISIT  
[SIBFL.NET/SUNNYSACES.](https://sibfl.net/sunnyspaces)**



SUNNY

SPACES

*Islander*

**PUBLISHED BY THE CITY OF SUNNY ISLES BEACH  
CULTURAL & COMMUNITY SERVICES DEPARTMENT**

18115 North Bay Road, Sunny Isles Beach, FL 33160  
[305.792.1706](https://305.792.1706) | [sibfl.net](https://sibfl.net)